

NEXANS Radiant Floor Warming & Heating

Homeowner's Guide and Installation Manual -- TXLP Cable

NEXANS provides warmth and comfort in all residential and commercial areas in which ceramic tile, marble, slate, vinyl, carpet, laminate, hardwood or virtually any type of flooring is being installed. This includes any area from bathrooms to kitchens and atriums; breakfast and dining areas, foyers, sun rooms, basements and a variety of spaces where warm floors make a welcome addition. Only your imagination limits your use of NEXANS cable.

NEXANS can be installed on any sub-floor surface prepared to TCA, (Tile Council of America) standards. The NEXANS cable is set directly under tile or stone in the setting mortar, (generally of thinset variety). The heating cable and thinset is so thin that it will add little more than 3/16" additional depth to the finished installation. Call and ask our technical staff for application assistance on other applications.

The NEXANS TXLP cable consists of a solid copper resistance wire wrapped in a layer of thermoplastic insulation. The insulated element is further protected by a tinned copper grounding shield. The armoured heating element is then wrapped in a steel shield. The cable can be easily formed and adapted to almost any geometrical floor shape, to suit your room. This design utilizes the most advanced materials and is the most easily installed cable available for residential or commercial renovation and new construction.

NEXANS is a CSA listed floor warming cable. It is warranted free from manufacturer's defect for 10 years (see our written Limited Warranty for details), maintenance free, safe, silent, energy efficient and, once installed, is totally out-of-sight. While a variety of controls can be used with the NEXANS floor warming system, we strongly recommend using a thermostat with a remote floor temperature sensor. This form of control affords the greatest comfort and control of your installation.

These features are only a few of those which make NEXANS the most versatile, easy to install, reliable and profitable to sell floor warming system available.

The following pages will provide you with an overview of how NEXANS works, how it is installed and maintained as well as the benefits of this complete floor warming system. Take a few moments to review this information. If you have further questions, one of our floor-heating professionals will be happy to assist you.

Homeowner's Information

General Instructions:

The electrical connection of the NEXANS TXLP cable must be performed by a qualified electrician in accordance with the National Electrical Code. The installer has been instructed to provide you with a plan of the system installation. The plan shows where the heating element is installed, the location of the optional floor temperature sensor and the electrical description of the system. Keep the plan for your system and a copy of these instructions for future reference. Future homeowners should also receive this information.

No penetrating fasteners (such as nails or screws for doorstops, toilets, etc.) may be installed through the area warmed by the cable.

To optimize the comfort efficiency of the NEXANS system, throw rugs thicker than 1/2" should not be used over the heated area. Additionally, built in cabinets, appliances and other furniture with solid bases should not be placed on warmed areas of the floor. Make sure your installation is planned to use the heating cable only in the areas of the room on which persons will walk and with a minimum distance of 3" to 4" from the walls.

Temperature Control:

A thermostat which monitors and controls the floor temperature through a remote sensor, mounted in the floor at the time of installation, is a recommended option. On floor areas where the heating load surpasses the amp capacity of the thermostat (3840 watts at 240 volts), you must install a relay to operate the heating system.

Maintenance:

Periodically, the GFCI (Ground Fault Circuit Interrupter) which is required in all installations should be tested to insure its continued operation.

NEXANS has no moving parts. The system is virtually maintenance free. If the system does not appear to be heating properly, refer to the troubleshooting guide in this manual or call your installer

Installer's Guide to Installation

General Instructions:

These instructions must be followed when assembling and installing the NEXANS system. Make them available to the installer working on the project and when finished turn them over to the homeowner for future reference. Failure to follow these instructions may void the warranty on the installed system.

Important Installation Considerations:

The electrical connection of the heating system and the thermostat should be done only by a qualified electrician in accordance with the National Electrical Code and with local codes.

To assure safety, the NEXANS floor warming system **must** be connected to the electrical service via an approved GFCI (Ground Fault Circuit Interrupter).

The heating system may be installed over concrete, wood or any existing, sub-floor.

Walking on the NEXANS heating element during installation should be minimized and done only with rubber-soled shoes.

Penetrating fasteners such as nails or screws may not be installed through the areas of the heating element.

The NEXANS heating element should not be laid across expansion joints of the sub-floor.

While installing the NEXANS heating cable, avoid crimping or overly sharp bending of the heating element cable.

Planning the Installation

The NEXANS heating element must not be installed under cabinets, appliances or plumbing fixtures which are permanently installed and attached to the floor. Use special care when designing systems for bathrooms, kitchens, saunas or other rooms in which permanent fixtures will be installed.

Built-in cabinets and other furniture and fixtures with solid bases must not be placed on the heated portion of the NEXANS system. Plan the installation to cover only those areas of the floor which will be walked on.

Placing carpets thicker than 1/2" on the NEXANS heated area should be avoided. Such carpets and throw rugs will act as insulators over the heated area, reducing the warming efficiency of the installation.

NOTE: To avoid damage to the heating element during installation, care must be taken that tools or tiles with sharp edges or points are not dropped or used carelessly on the element.

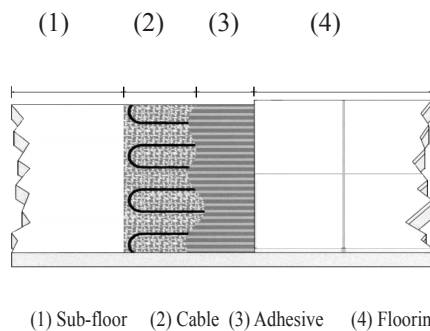

Figure 1.

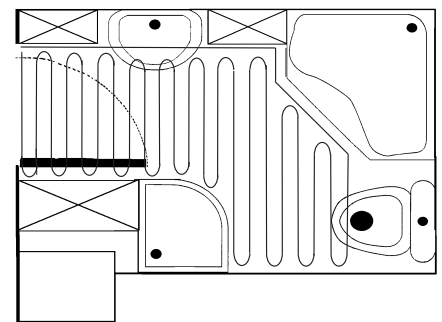

Figure 2

Before laying the Nexans cable, make a drawing of the installation plan for each room.

Show the locations of:

- The Nexans cable
- The cold leads of the power connection cable
- The temperature sensor
- All fixed appliances, toilets, vanities, bookcases, etc..

When planning the layout of the cable make sure that fixed objects will not be installed over the heating cable.

The installation plan must be given to the homeowner and attached to the breaker box.

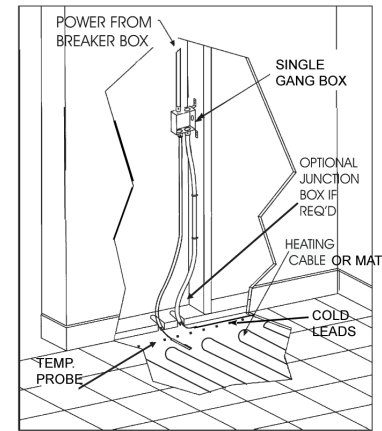

Figure 3

The National Electrical Code (NEC) requires that heating mat cold leads must be protected in conduit or Greenfield when they extend above the floor (see also local codes). When a remote floor sensor is used, a separate empty 3/8" conduit should be installed. Cold leads should not be placed in the same conduit as the sensor. Plastic bushings should be used where cold leads and sensors enter conduit to protect the wires.

IMPORTANT: The floor sensor should be secured in the sub-floor only after heating mat has been secured to the sub-floor. This will allow you to place the sensor properly between the heating element wires.

LAYING OUT THE HEATING CABLES

Determine the square footage of the area to be heated.

Use the formula to determine spacing of cable as follows:

Spacing:

$$\frac{\text{Area (Sq. Ft.)} \times 12}{\text{Cable Length}} = \text{Spacing}$$

Example: Area in square feet - 85 sq. Ft
 Cable Length - 193 ft.

$$85 \text{ sq. Ft.} \times 12 = \frac{1020}{193} = 5.28'' \text{ on center}$$

The Cable

The cable consists of a solid copper heating element that runs through the centre, an insulator surrounding the core conductor, a silver colored, stranded ground wire, that is again insulated, a metal shield and an outer insulation layer.

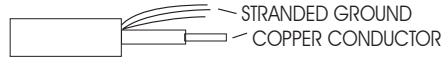

The centre conductor is the part that is hooked up to the thermostat, this is the part used to test cable resistance. The cable has a unique "hidden splice", that is marked "SPLICE" and is located approx. 8 feet in from each end of the cable. This is where the unheated portion of the cable (with the snowflakes), meets the heated portion. Heated portion can NOT be run behind a wall, it must be all buried in the floor.

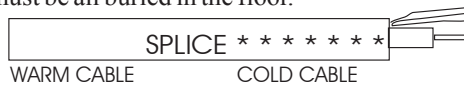

DO NOT CUT THE HEATED PORTION OF THE CABLE.

Fastening Cable to Floor

The cable may be held to the floor by tying onto mesh, stapling onto wooden sub-floor or using the optional cable mounting track available from the dealer. The track may be nailed or screwed onto the floor at approx. 3 foot centres. On concrete floors you may also use a hot glue gun to secure the cable to the floor. It may be wise to sketch the cable and track layout on a piece of paper before starting.

It is important to plan that the cable finishes at the same point it started, which is usually directly below the thermostat. This is where the first splice is laid. Start by laying the cable from the thermostat, stay 3" from the wall and run the cable around the perimeter to the far side of the room. Then start the series of "S" loops on the floor working back towards the thermostat, maintain the calculated spacing as you go. If, for instance, the spacing is 6" on center (OC), lay the first cable 3" from the wall, the second cable loop will be 9" from the wall. Use one half OC spacing from all obstacles, stay 8" away from toilet wax seal. Proceed laying cable in the "S" pattern, maintain full spacing over balance of area to be warmed.

A custom cable will have black/white cold leads.

The cold lead wires can be field cut at any point, but never cut the heated portion (past the splice) as this will damage the cable.

The splice must be buried in the masonry! This is the point at which the heating cable is attached to the cold leads. Only the cold leads can be out of the masonry or concrete and run into the walls or conduit.

The thermostat sensor should be installed between the heating cables, a minimum 12" into the heated floor area.

DO NOT CROSS WIRES OVER EACH OTHER



Testing the System Resistance:

Before setting the heating cable, measure the resistance with an Ohmmeter (see attached chart) and note the value on the system installation plan. After completing the heating

system installation, measure the system's resistance again with the Ohmmeter.

Compare the new reading with the first measurement to assure they are identical and no damage has occurred to the heating cable during installation. Mark the measured resistance on the attached card and fasten to the circuit breaker box.

IMPORTANT: The system warranty is not valid without evidence that the system resistance has been tested.

Securing the Heating Cable

Follow the Tile Council of America recommendations when planning how you will secure the heating cable. Selected adhesives (tile setting mortar) should be applied to the floor according to the manufacturer's instructions. The heating cable should be laid carefully, do not cut or crimp the cable. While laying the heating cable, take note of where you will position the floor sensor.

The system's cold lead wires, as well as the wire from the remote sensor, are run to the junction box either through a groove prepared in the sub-floor or through conduits (as local electrical code requires).

BE SURE THE COLD LEADS NEITHER CROSS NOR TOUCH THE HEATING ELEMENT WIRES.

After securing the heating cable to the sub-floor, measure the system's resistance again with the Ohmmeter. Compare the new reading with the first measurement to assure they are identical and no damage has occurred to the heating cable during installation.

Need for a Protection Layer over the Heating Cable:

In projects which are not immediately floored over the heating cable installation, a protective layer of self leveling concrete is applied over the cable to protect it until the tile is laid. For this layer, use an upgraded concrete into which acrylics are mixed to give the mortar the required elasticity and resistance to stress. These products can be found at your tile supplier, as per Tile Council of America.

When the installation is complete, the tile or stone surface can be laid directly over the protective layer without further preparation, using any TCA approved setting mortar.

When applying the various layers be sure to follow the manufacturer's directions for the mortar product.

Measure the system's resistance with an Ohmmeter. Compare with previous readings to assure no change has occurred.

NOTE: Be sure to observe recommended cure times for your installation. Ceramic tile installation may require 10 to 14 days to cure before the NEXANS floor warming system may be operated.

Choice of Floor Covering:

The NEXANS floor warming system is specially designed to be used with hard floors such as ceramic tile, marble or other stone floorings. Discuss its use with any other floor coverings with your NEXANS representative.

NEXANS Radiant Floor Warming & Heating

Homeowner's Guide and Installation Manual -- TXLP Cable

Mounting the Output Plate:

After completing the NEXANS floor warming system installation, mark the final measured resistance on the output plate. Mark the cable location on the installation plan which is given to the homeowner with the homeowner instructions and installation manual.

System Control Options

Wall mounted thermostat (line voltage) with remote sensor: A wall mounted 240V thermostat with a remote sensor, which can be mounted in the floor (see figure 8), offers the best way to regulate your system. The sensor should be installed halfway between the cables, on center, at least 12" into the heating cables serpentine arrangement, while ensuring that it does not cross any of the heating wires. By controlling the actual floor temperature, the system can be adjusted to the temperature which is the most comfortable for the situation.

Through this method, the floor temperature can be controlled as desired with little variation. The line voltage thermostat connects to the junction box, as marked in figure 3.

Trouble Shooting

CAUTION: TURN OFF ELECTRICITY BEFORE TROUBLESHOOTING SYSTEM

1. If the system fails to heat, make sure the GFCI (Ground Fault Circuit Interrupter) has not been tripped. If it has, find the fault

2. Check for continuity with an Ohmmeter. Compare the reading with the resistance marked on the Output Plate. Lack of, or reduced, continuity may indicate a break in the system.

3. Make sure the breaker or fuse is delivering power to the system.

If your system fails to heat after these checks call your installer. Be sure to tell the installer the Model Number of your system. This will be found on the warranty card attached to the circuit breaker box door.

This schematic is meant as a preliminary guide only. Refer to the instructions provided with the thermostat GFCI, and timer. All electrical work should be performed by a licensed electrician.

WARNING

THE FLOOR HEATING SYSTEM IS DESIGNED TO BE INSTALLED WITH A GFCI (GROUND FAULT CIRCUIT INTERRUPTER). Failure to do so may result in injury. This system may not be energized unless the system is installed according to the enclosed instructions. The installation must meet or exceed all local and national electrical codes.

NOTE: The thermostat and optional timer must be mounted in individual standard single gang boxes. Because of the face plate dimensions of each item, a dual gang box will not accept both units together in the same box.

Floor Layers

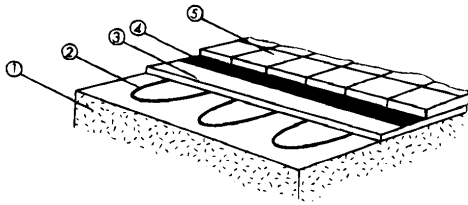

1. Existing subfloor
2. Alcatel heating cable
3. Thin set mortar
4. Membrane (if needed)
5. Tiles

Heating Cables in Wheel Tracks

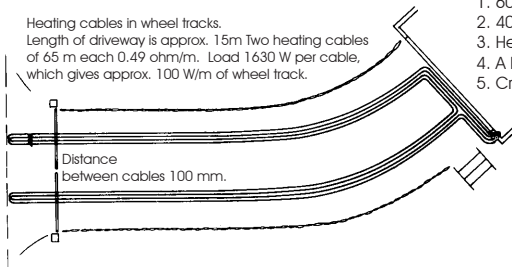

1. 60-80 mm concrete paving stones.
2. 40-50 mm sand.
3. Heating cable
4. A layer of 20 mm asphalt.
5. Crushed stone.

THERMOSTAT WITH INTEGRAL GFCI

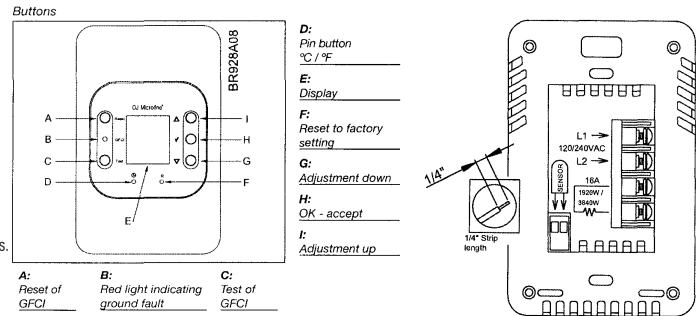

Figure 4

Resistance Chart

TXLP/1 TYPE	Resist. Ohms	Resist. Ohms/M	Length Meters	Length Feet	120V Watt	208V Watt	220V Watt	230V Watt	240V Watt
300/17	176.00	10.00	17.6	58	80	245	275	300	330
400/17	132.07	5.62	23.5	75	120	330	365	400	435
500/17	105.84	3.60	29.4	96	140	410	460	500	545
600/17	88.25	2.50	35.3	115	165	490	550	600	650
700/17	75.81	1.84	41.2	135	190	570	640	700	760
850/17	62.00	1.24	50.0	164	230	700	780	850	925
1000/17	52.92	0.90	58.8	193	270	820	915	1000	1090
1250/17	42.63	0.58	73.5	241	340	1020	1145	1250	1360
1400/17	37.86	0.46	82.3	270	380	1145	1280	1400	1525
1750/17	29.84	0.29	102.9	338	480	1430	1600	1750	1905
2200/17	24.59	0.19	129.4	424	600	1800	2015	2200	2395
2600/17	20.30	0.13	156.1	512	710	2130	2380	2600	2830
3100/17	17.10	0.09	186.0	610	850	2540	2840	3100	3375
Approximate Watts/Meter =====>					4.6	13.9	15.5	17.0	18.5
Approximate Watts/Foot =====>					1.5	4.2	4.7	5.2	5.6

NOTE: Thermostats, timers and snow melt controls, cable mounting track and 1110 boxes are available from your NEXANS dealer.

Heating Cables on Stairs

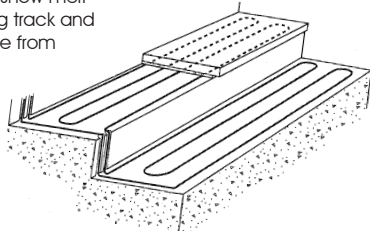

Nexans distributed in Canada only by:

Britech Corp

515 Milner Ave, Unit #3, Toronto, Ontario M1B 2K4

Phone: 416-335-7790 Fax: 416-335-8071 Toll Free: 877-335-7790

E-mail: info@britech.ca

www.britech.ca